

Nitrogen starting systems for diesel engines



- Suitable for starting engines up to 320 litres in hazardous areas
- Compact solution using interchangeable gas bottles

IPU nitrogen start packages

IPU nitrogen starting modules are designed for starting diesel engines in conjunction with a pneumatic starter motor. As nitrogen is an inert gas, it provides the ideal solution for emergency back up to the primary starting system on applications such as fire pumps or generators in offshore and hazardous areas where secondary starting is essential.

IPU nitrogen starting systems utilise standard high pressure rental nitrogen cylinders to store the energy used for starting. The benefit of using nitrogen cylinders is that when empty they can be exchanged for full cylinders.

As these cylinders can store nitrogen at up to 350 bar, a large cranking duration can be achieved from each nitrogen cylinder which can then simply be replaced. IPU manufacture the starting system to accept the required number of standard rental nitrogen cylinders (not supplied by IPU Starting) needed to provide the specified cranking period.

Nitrogen starting systems use the stored pressure in the nitrogen cylinders storing at up to 350 bar to turn a pneumatic starter motor, which typically operates at 7 bar using a high-pressure full flow pressure reduction valve.

Applications

Nitrogen starting packages are used extensively offshore where a simple but effect method of starting a diesel engine is required. Main applications are for fire pumps on offshore platforms, which require multiple methods of engine cranking.

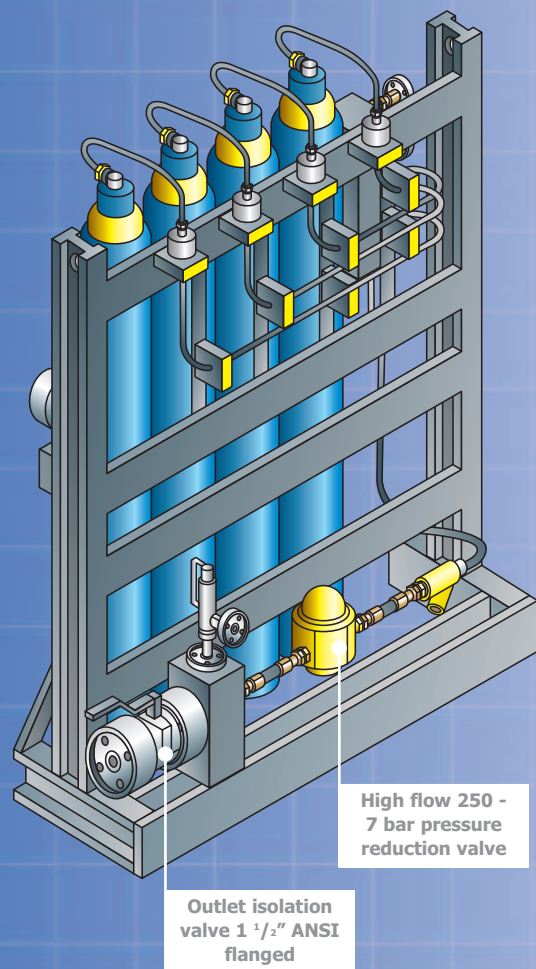
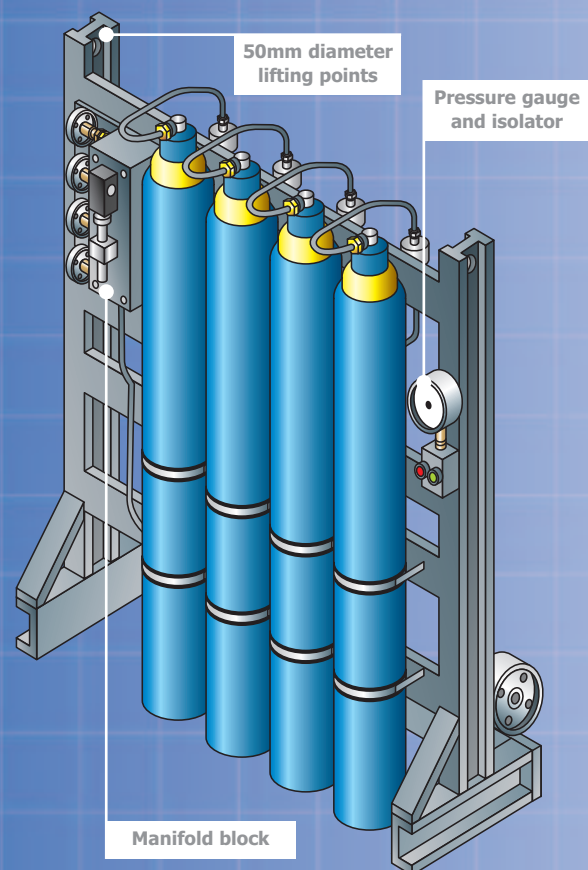

Technical information

The nitrogen starting modules are fully assembled and ready to use, with all components mounted within a freestanding skid, typically comprising of:

Nitrogen bottles (provided by the end user)

250 bar to 7 bar full flow pressure reduction valve

High pressure filter

Manifold block incorporating:

- Pressure safety valve to protect the low pressure items in case of reduction valve leakage or failure
- High and low pressure gauges and stainless steel isolators
- Isolation valves for each nitrogen cylinder
- Low pressure switch and stainless steel isolator (M20 conduit entry) set to 70 bar approximately

Hoses with nitrogen cylinder adaptors to connect to each cylinder.

All items are mounted into a fully welded steel frame with two off lifting points. All fittings are stainless steel Swagelok twin ferrule type with stainless steel tubing, and paint finish is to IPU standard offshore paint specification.

Typical nitrogen starting schematic

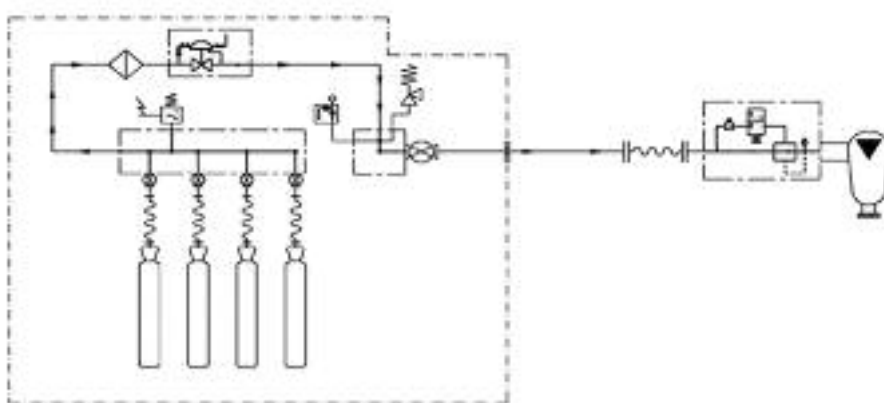

High flow pressure reduction valve

Our starting solutions operate in some of the harshest environments in the world – situations where electric starting would not offer the guarantees our customers demand. The division designs and manufactures bespoke solutions as well as distributing from leading names in the field.

Our starting product portfolio includes:

- Hydraulic starting systems
- Air compressor systems
- Spring starting
- Nitrogen starting
- Air starting

Useful contact numbers

IPU Engine Starting

David Caddick

Divisional Director

Office: +44 (0) 121 511 0400

Fax: +44 (0) 121 511 0402

Mobile: +44 (0) 7831 582978

Email: david.caddick@ipu.co.uk

Jon Cheetham

Global Account Manager

Office: +33 (0) 254 726 300

Mobile: +44 (0) 7825 944050

Email: jon.cheetham@ipu.co.uk

Nigel Hampson

Global Account Manager

Office: +44 (0) 121 511 0400

Fax: +44 (0) 121 511 0402

Mobile: +44 (0) 7500 841263

Email: nigel.hampson@ipu.co.uk

Wenkui Liao

Business Development - Far East

Office: +44 (0) 121 511 0400

Fax: +44 (0) 121 511 0402

Mobile: +44 (0) 7826 872610

Email: wenkui.liao@ipu.co.uk

Réne Sowald - Kuala Lumpur Office

Sales Account Manager

Mobile: +44 (0) 7825 944048

Email: rene.sowald@ipu.co.uk

No. A-29-05, Marc Service Residence

No. 3, Jalan Pinang

50450 Kuala Lumpur

Malaysia

IPU GROUP Engine Starting Division

Visit our Group website www.ipu.co.uk

IPU Group, Churchbridge, Oldbury,
West Midlands, B69 2AS England

T: +44 (0) 121 511 0400 **F:** +44 (0) 121 511 0401

E: ipu@ipu.co.uk www.ipu.co.uk

