

Air start turbines for diesel engines

JETSTREAM



- Pre-engaged and inertia for marine & offshore
- Starts diesel engines up to 80 litres
- Operates between 3-30 bar pressure





Introduction

Jetstream 4 and 5, the NEW generation of air turbine starters are simply the most rugged starter for diesel engines and generators in marine, offshore and land based environments. Developed as an easy to install, fit-and-forget solution, Jetstream is guaranteed to start any make of diesel engine up to 80 litres.

Available as either a pre-engaged or inertia model, Jetstream starters are capable of operating at different pressures from 30 bar down to 3 bar, allowing you to either use your existing air supply, save cost by removing the need for reduction valves or minimise the size of air tanks in confined spaces.

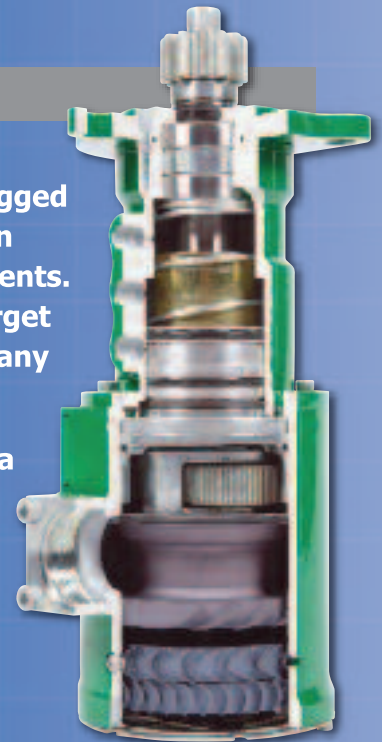

JETSTREAM

Not just tough, Jetstream is lightweight, powerful and compact. With an all-new highly efficient four-stage turbine mechanism Jetstream provides an improved level of performance and reliability. Manufactured from high-grade aluminium, electroplated alloy steels and encased in rugged cast iron, Jetstream is highly resistant to corrosion making it ideal for marine and offshore applications. Unlike vane type starters, Jetstream's turbines are more resilient against wear and damage, needing no lubrication and are totally maintenance-free.

Available in two different sizes and three pressure ratings, the Jetstream 4 can be provided as either inertia or overhung pre-engaged dependent on the environment intended, whereas Jetstream 5 is available pre-engaged overhung.

Jetstream simply gives you more. You can now specify starting solutions that work between 30 bar down to 3 bar, saving money on reduction

valves or minimise air tank size in confined spaces. Either way you can choose more solutions from a single source to accommodate a diverse range of engineering applications.

The Jetstream is a culmination of specialist industry knowledge combined with a unique blend of engineering innovation and in-depth customer understanding. With an outstanding pedigree established within the harsh South African mining industry, Jetstream has been created to deliver beyond the expectations of engineers around the world. The result is improved performance, increased choice and total reliability.

**Choice of
two sizes
and three
pressure ratings**

How Jetstream air starters work

The all-new turbine works by allowing a stream of compressed air to enter the casing of the unit and be guided via the inlet nozzles to strike the primary turbine wheel. On impact with the primary wheel, the air velocity is transferred making the wheel rotate at very high speed. This effect is repeated as the air exits the first wheel and strikes each subsequent wheel, finally reaching speeds between 25 to 40 thousand rpm. This velocity is reduced by about 10:1 inside a planetary gearbox sitting just in front of the turbine mechanism.

**Start any
engine,
at any
pressure
in any
environment**

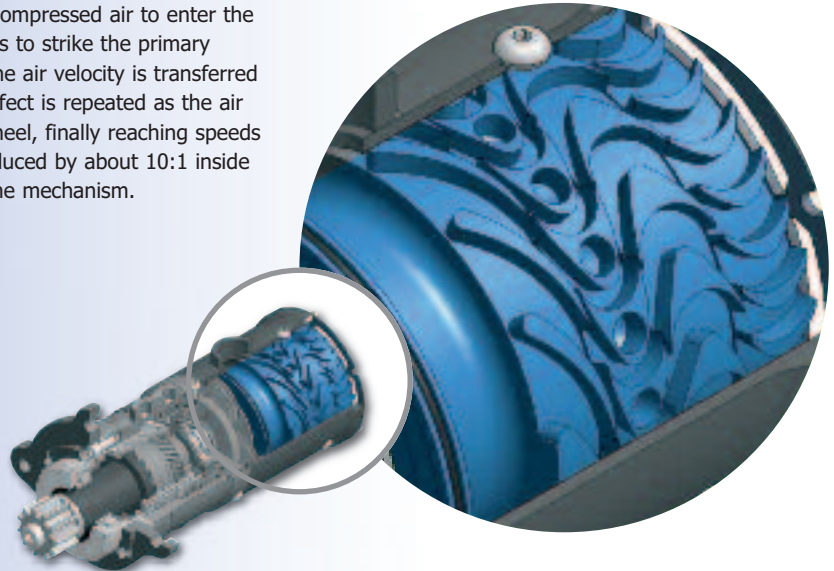

Air starters applications



The Jetstream is unique in being capable of starting any engine, at any pressure in any environment. Suitable for all applications, choose from either an overhung pre-engaged model or inertia model whichever suits your specific requirements and environmental conditions best.

The inertia starter

incorporates a gear, which is free to rotate around a helical thread. With the inertia generated by the starter motor suddenly accelerating, this gear moves forward on the helix until making contact with the engine's ring gear. This starter has the advantage of using the extremely rugged and proven spring drive that is used on our hydraulic starter range making the starter very resilient in harsh or dirty conditions. By incorporating proven and less complicated parts the inertia starter is the low cost hard wearing answer to demanding applications.

The pre-engaged starter

is equally durable but eliminates the possibility of sparks making it ideal for environments involving explosive atmospheres. Before starting, the starter pinion engages the ring gear and only when the pinion is in its totally forward position will the starter motor begin to crank the engine. This has the advantage that the starter only rotates once the gears are engaged, reducing the potential for sparks and meeting EN1834-1:2000 regulations for offshore use. This risk can be further removed by using a beryllium copper non-spark pinion. The pre-engaged starter is the perfect solution when dealing with limited space engines delivering performance and safety in equal measures.

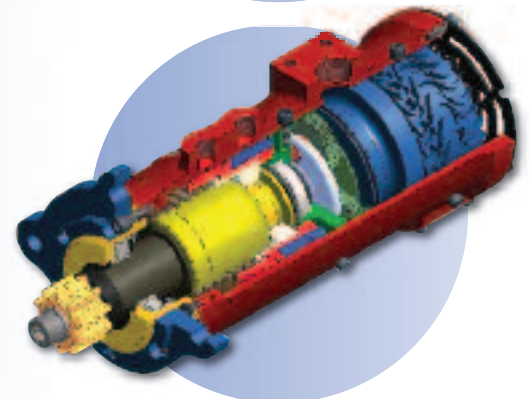
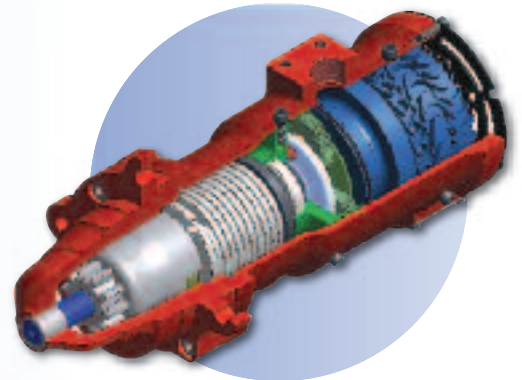

ATEX approved



IPU air starters comply with EU legislation (ATEX Directive) for safe operation of equipment in potentially explosive environments. The Jetstream range of starters have been independently tested and comply fully with stringent criteria set out in directives EN13463-1, EN13463-5 and EN1834-1:2000.

Product features

JETSTREAM 4

- Available as PRE-ENGAGED with overhung pinion or INERTIA with outboard bearing. Pre-engaged is suitable for ATEX requirements (EN1834-1)
- Suitable for engines up to 10–12 litres
- Inertia starters use heavy duty spring drive proven in hydraulic starters for 30 years
- All J4's can be ordered complete with integrated relay valve and exhaust adapters or mufflers, reducing fitting and installation time
- J4 is available in 3 pressure configurations-
 - Low pressure suitable for operation down to 3 bar
 - Medium pressure up to 10 bar inlet pressure
 - High pressure up to 30 bar inlet pressure
- Exhaust options: simple guard, straight or 90° threaded adapters to suit piping or mufflers
- Sealed for life turbine section eliminates maintenance

J4 PRE-ENGAGED
with integrated
relay valve and
90° muffler

J4 INERTIA
with integrated
relay valve

JETSTREAM 5

- Available as PRE-ENGAGED with overhung pinion suitable for ATEX requirements (EN1834-1)
- Suitable for engines up to 80 litres
- All J5's can be ordered complete with integrated relay valve and exhaust adapters or mufflers, reducing fitting and installation time
- J5 is available in 3 pressure configurations-
 - Low pressure suitable for operation down to 3 bar
 - Medium pressure up to 10 bar inlet pressure
 - High pressure up to 30 bar inlet pressure
- Exhaust options: simple guard, straight or 90° threaded adapters to suit piping or mufflers
- Sealed for life turbine section eliminates maintenance
- The J5 has easily removeable and changeable pinion and flange for simple engine adaptability. No disassembly required to change pinion and flange.

J5 PRE-ENGAGED
with integrated
relay valve

J5 PRE-ENGAGED
with integrated
relay valve and
90° muffler

Product performance

Performance figures at low and high pressure available on request.

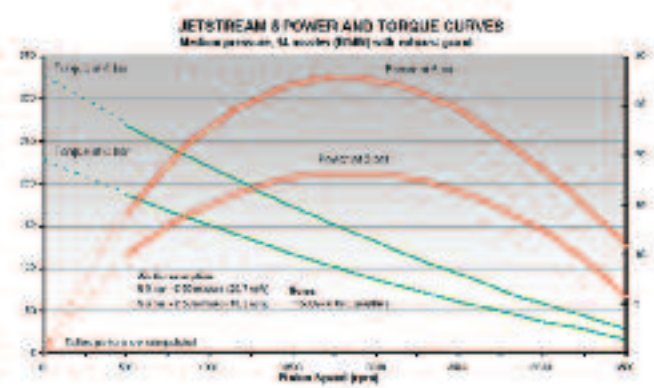
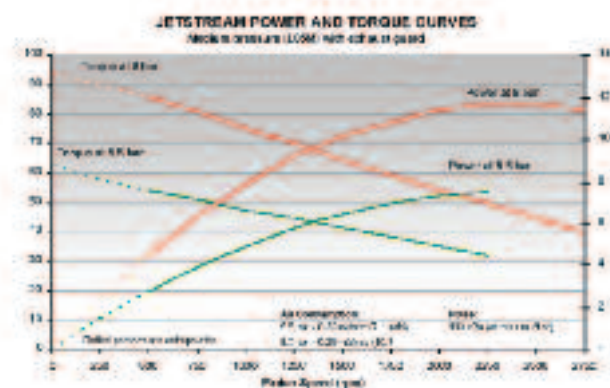

Product selection reference guide

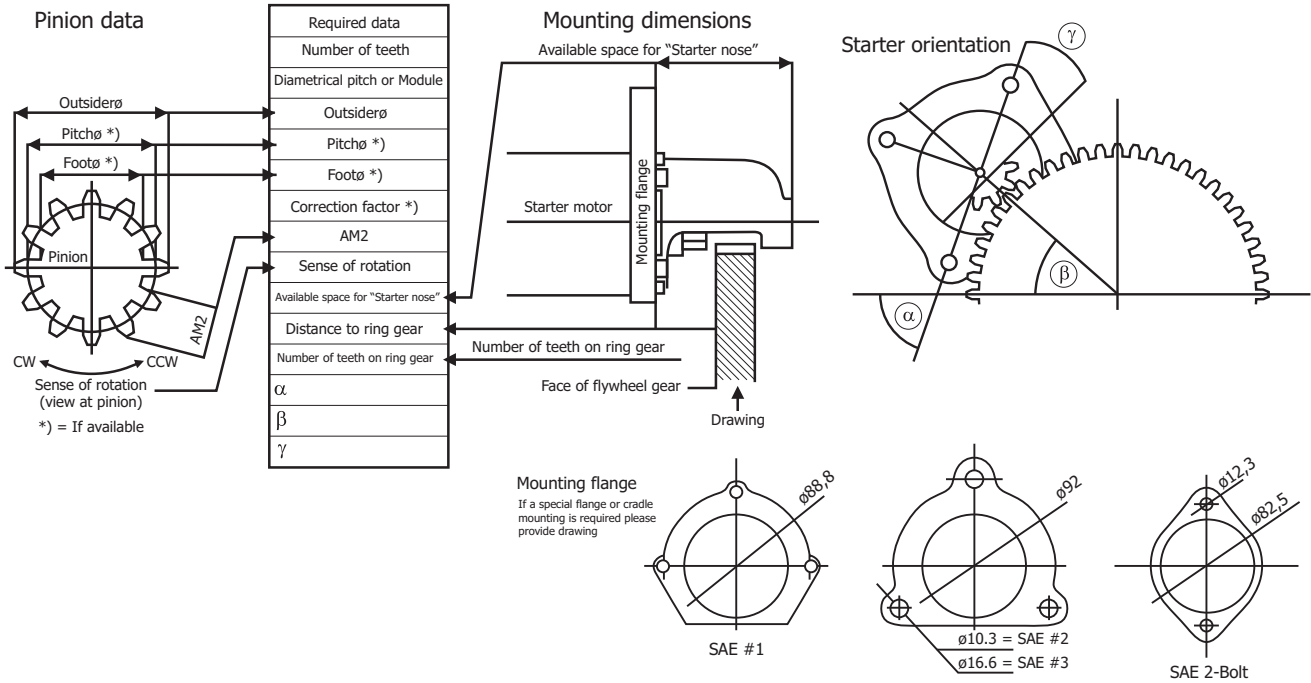

Product installation

The Jetstream with its integrated relay valve means assembly is quick and easy. Just attach the starter, connect the air and you're ready to go - the amount of time and skill needed to fit a Jetstream is much less than any other equivalent starter. If connected to nitrogen or gas, Jetstream can be supplied with a muffler or threaded port on the exhaust thereby reducing the noise and safely enabling the exhausted gases to be piped away.

Jetstream
J4/J5

Available for both
J4 and J5
Effective at all
pressure ratings

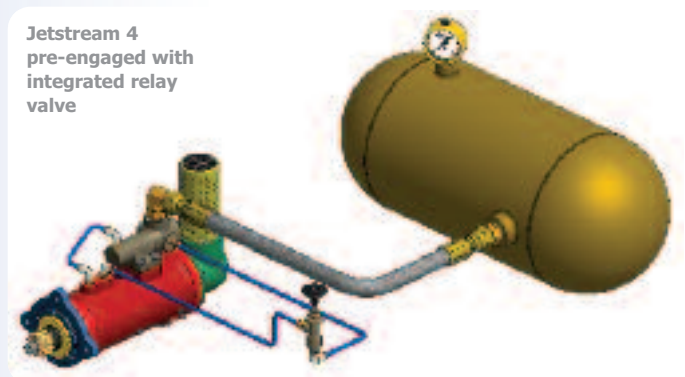
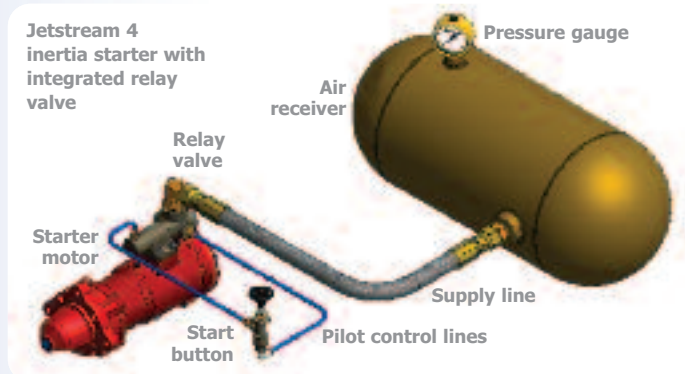

Our starting solutions operate in some of the harshest environments in the world – situations where electric starting would not offer the guarantees our customers demand. The division designs and manufactures bespoke solutions as well as distributing from leading names in the field.

Our starting product portfolio includes:

- Hydraulic starting systems
- Air compressor systems
- Spring starting
- Nitrogen starting
- Air starting

Useful contact numbers

IPU Engine Starting

David Caddick

Divisional Director

Office: +44 (0) 121 511 0400

Fax: +44 (0) 121 511 0402

Mobile: +44 (0) 7831 582978

Email: david.caddick@ipu.co.uk

Jon Cheetham

Global Account Manager

Office: +33 (0) 254 726 300

Mobile: +44 (0) 7825 944050

Email: jon.cheetham@ipu.co.uk

Nigel Hampson

Global Account Manager

Office: +44 (0) 121 511 0400

Fax: +44 (0) 121 511 0402

Mobile: +44 (0) 7500 841263

Email: nigel.hampson@ipu.co.uk

Wenkui Liao

Business Development - Far East

Office: +44 (0) 121 511 0400

Fax: +44 (0) 121 511 0402

Mobile: +44 (0) 7826 872610

Email: wenkui.liao@ipu.co.uk

Réne Sowald - Kuala Lumpur Office

Sales Account Manager

Mobile: +44 (0) 7825 944048

Email: rene.sowald@ipu.co.uk

No. A-29-05, Marc Service Residence

No. 3, Jalan Pinang

50450 Kuala Lumpur

Malaysia

IPU GROUP Engine Starting Division

Visit our Group website www.ipu.co.uk

IPU Group, Churchbridge, Oldbury,
West Midlands, B69 2AS England

T: +44 (0) 121 511 0400 **F:** +44 (0) 121 511 0401

E: ipu@ipu.co.uk **www.ipu.co.uk**

